

Smart Solutions To Keep You Moving!

The Premier Tilter is designed to increase the efficiency of vacuum unloading Gaylords or other containers. The automatic tilting feature allows for the smooth and continuous flow of material to the vacuum wand with little or no assistance from your operator.

This unit will lift up to 1000lbs at 80psi. However, the initial tilt weight can be set as required using the adjustable regulator.

Key features:

- Heavy duty frame
- Ground entry loading
- Firestone industrial air bag
- Parker pneumatic regulator
- Parker 3-position hand control valve
- 1" Flanged pivot bearings for smooth operation
- Vacuum wand holder
- Gaylord retainer
- Industry leading two year warranty on all parts and workmanship



See back page for additional options and specifications.

Premier Gaylord Tilter

Standard Features:

- Ground entry loading
- 3-position hand lever control
- Auto or manual tilt
- Flow control to adjust down cycle speed
- 44" x 44" 10ga steel deck
- Heavy duty frame
- 1" flanged pivot bearings
- Adjustable height vacuum wand holder
- Ensign Blue Epoxy

Optional Features:

- Foot control valve
- Plunger style inline valve
- Pneumatic vibrator w/ controls
- Safety ratchet
- Full tilt indicator switch & light
- Tilt table caster frame
- Custom options & sizes available
- Heavy Duty applications (model 10-9000)

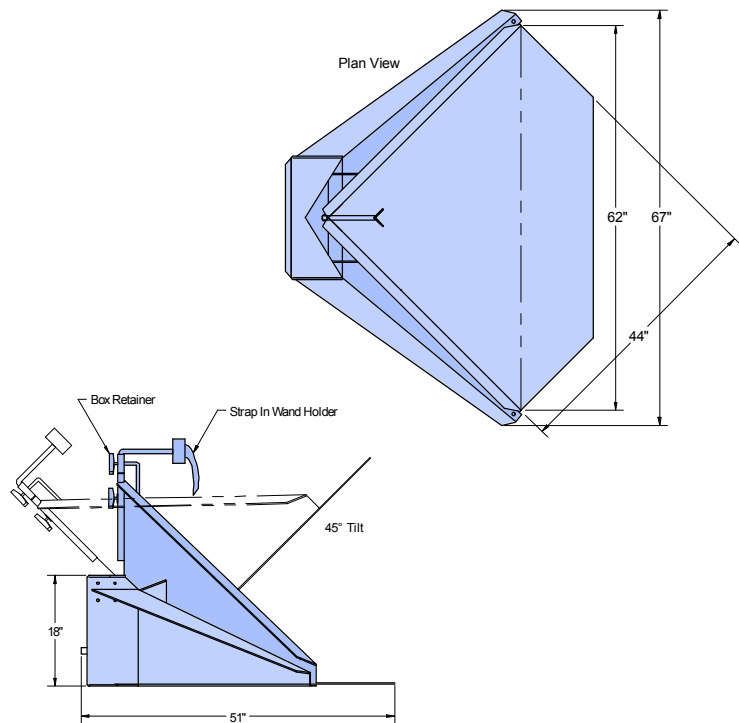
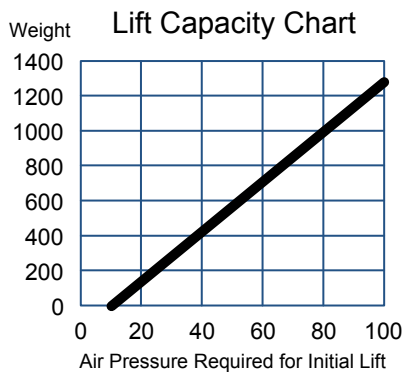

Model No.

Description

Max Lift

10-8500

Premier Ground Entry Tilter

1000lbs @ 80psi

10-9000

HD Premier Ground Entry Tilter

1600lbs @ 80psi

ENSIGN EQUIPMENT INC.
12523 Superior Court
Holland, MI 49424

ph: 616.738.9000 (or) 800.753.8947
fax: 616.738.9001

www.ensigneq.com
sales@ensigneq.com

